

# BUILDING A MODERN RAILWAY LINE IN THE GOTTHARD BASE TUNNEL

*Nicolas Steinmann, AlpTransit Gotthard AG, Switzerland*

*Patrick Favre, AlpTransit Gotthard AG, Switzerland*

## ABSTRACT

The Gotthard base tunnel, which will begin operating in 2011, will be the most impressive element of the new transalpine railway line through the Swiss Alps.

In view of the difficult accessibility and extreme climatic conditions, ensuring the fast and reliable transit of more than 300 trains per day through the two 57 km long single-track galleries represents a considerable technical challenge.

This paper illustrates the process of translating the constraints and design specifications of this project into appropriate technical solutions which it then outlines.

## 1 INTRODUCTION

On 29<sup>th</sup> November 1998, Swiss voters decided that the confederation should fund two new north-south railway projects : the Lötschberg and the Gotthard base lines. Both are intended to complement existing railway lines built at the end of the 19<sup>th</sup> century.

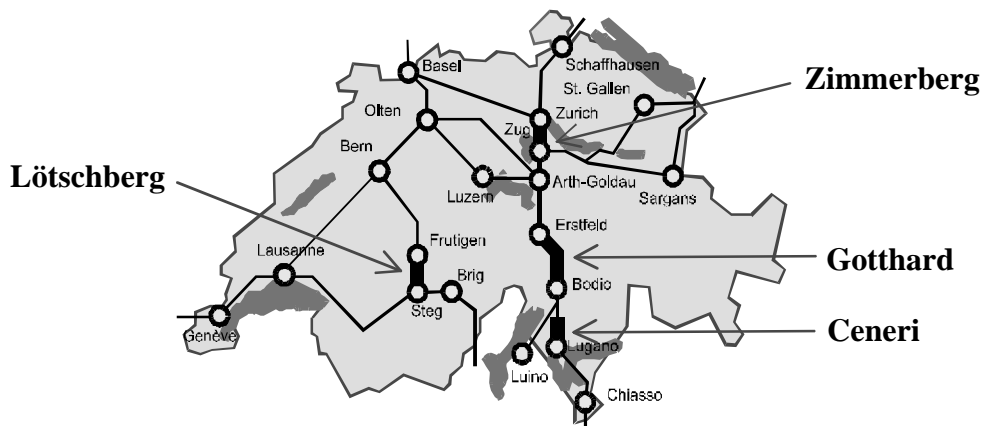

**Figure 1: North-South railway lines running through Switzerland**

The Gotthard base tunnel, which directly links the northern and southern sides of the Alps, is the most complex part of the new lines. It is one thing to excavate two 57 km long tunnels through a mountain under 2'000 m of rock - a feat in itself - but quite another to have high speed passengers trains and heavy goods trains run through them which is, of course, the ultimate goal of the project.

## 2 «RAILWAY EQUIPMENT»

A railway system usually consists of the following elements:

- A track for guiding the train
- Electrical power brought from the distribution network to the train by the catenary
- A signalling system (e.g. light signals and points control) for the regulation and the safety of the traffic
- Rolling stock (e.g. a locomotive pulling wagons or passenger cars)

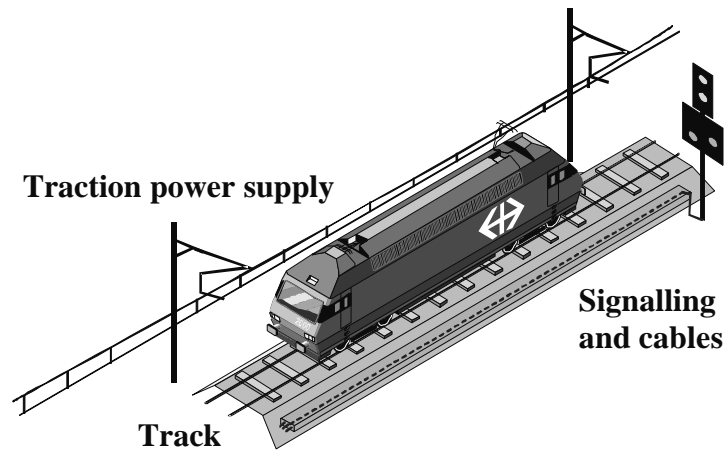
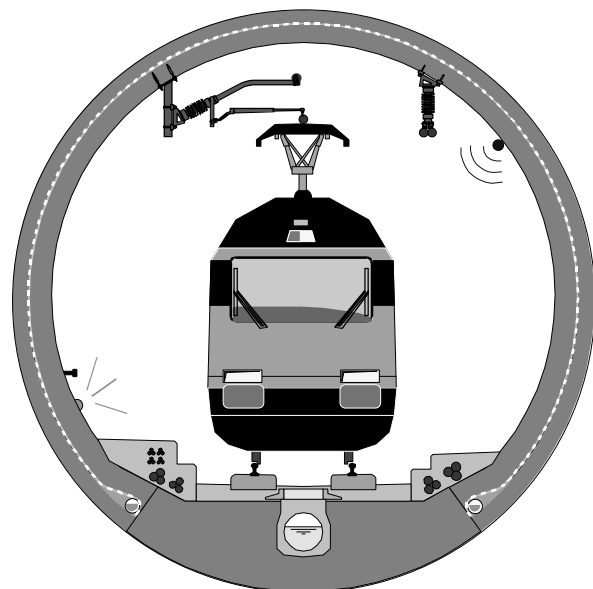

**Figure 2: The components of a common electric railway system**

In the specific case of tracks running through modern tunnels, some additional components are usually found, such as :

- A specific power supply network for operation and maintenance of the system
- Special antennas or *leaky feeders* for radio transmission
- A drainage system for evacuating ground water and water falling from trains
- Sidewalks
- A lighting system for «pedestrians»

The longer the tunnel, the more influence these particular elements have on its design and construction, and the more important they are for the operation of the line. These components, together with the specified vehicle gauge, determine the overall diameter of the tunnel.



**Figure 3: Specific components in a railway tunnel**

### 3 THE NEW GOTTHARD LINE COMPARED WITH TODAY'S LINE

Today's Gotthard mountain line, with its 15 km long tunnel, was originally used by steam trains, and began operating in 1882. The diagram below shows the new base line (max alt. 550 m) which is much lower than the old one (alt. 1'150 m). The new line between Altdorf and Biasca (65 km) is much shorter than the old line (96 km) with its circular tunnels.

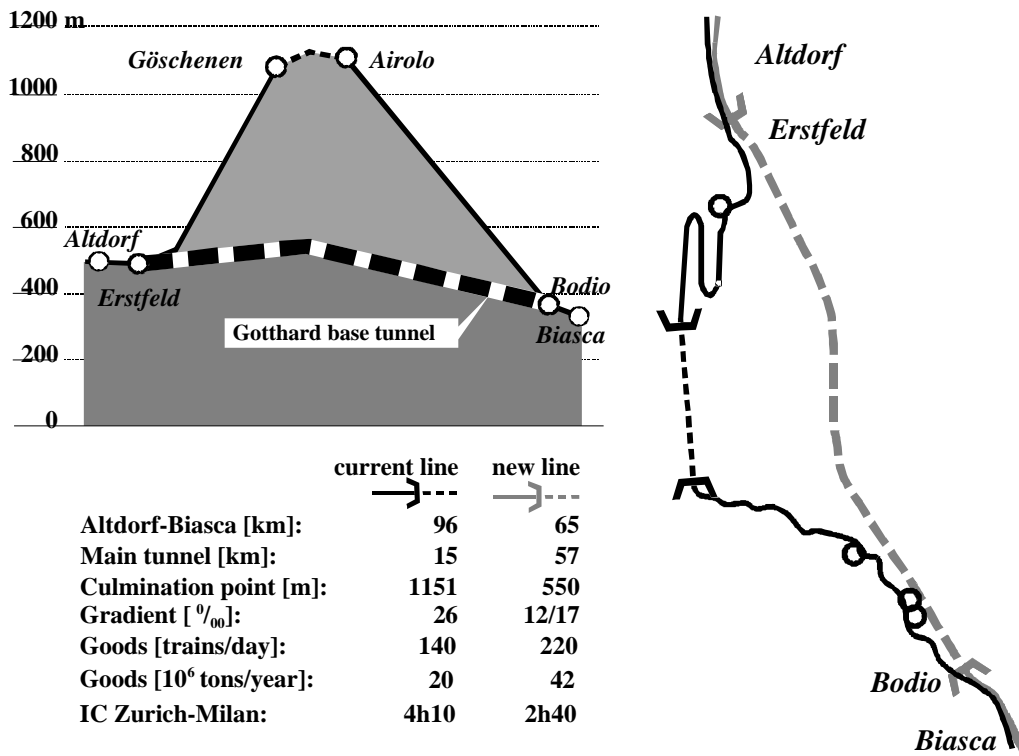

**Figure 4: The new Gotthard line compared to the current line**

As soon as the three main constituents of the new Gotthard lines are completed (the northern Zimmerberg tunnel, the Gotthard tunnel and the southern Ceneri tunnel), the line's transport capacity will increase considerably. The capacity will then only be limited by the access lines and the main goals of the project will then be achieved :

- Massive increase in goods transit capacity (twice as much as today)
- Much shorter North-South transit time for passengers and freight
- Reduced traction power requirements, per weight unit of transported goods, as a result of the elimination of steep slopes

Provided that the access lines are upgraded, future freight transit capacity and transit time can be further improved.

## 4 DESIGN SPECIFICATIONS

The design specifications are determined by the project environment as illustrated by the following picture:

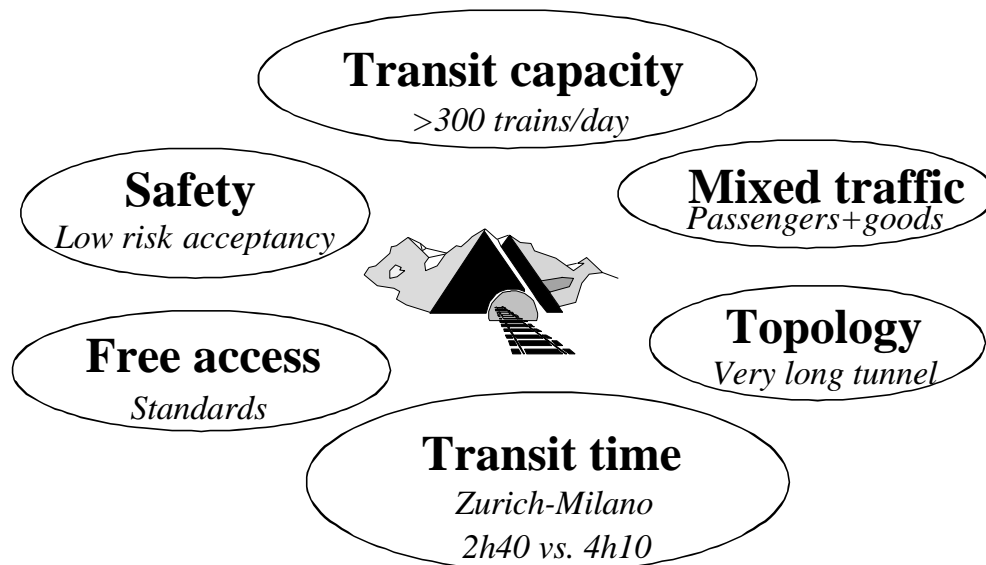
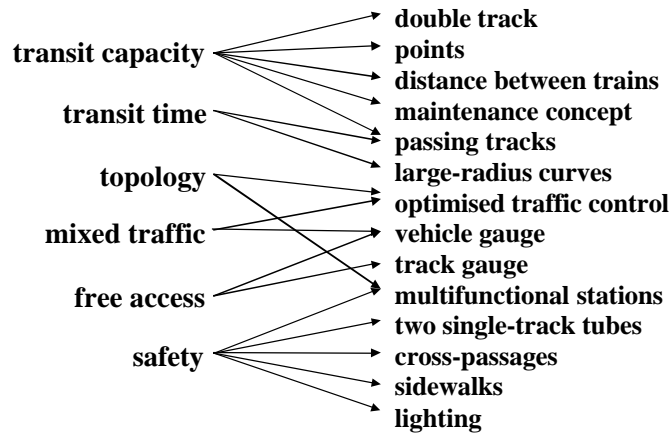

**Figure 5: Design specifications for the new Gotthard line**

- **Total transit capacity:** 220 goods trains and more than 100 passenger trains per day (including trains running on the old line which will not be discontinued); freight transport capacity of 42 million tons per year which will rise to 56 million as soon as the access lines are upgraded. The line's annual capacity today is 20 million tons.
- **North-south transit time** for passenger trains: Zurich-Milano will take 2:40 hours instead of 4:10 hours nowadays.
- **Mixed traffic:** goods and passenger trains circulating 24 hours a day.
- **Interoperability («free access»):** according to the new railway laws in the European Union and in Switzerland, any rolling stock operator can use the tunnel provided he fulfils the standards specified by UIC/STI/CENELEC.
- **Safety:** in case of an emergency in such long tunnels, the problem of passenger evacuation is very complex and passengers' subjective sensitivity to risk is very high. These phenomena have resulted in the project's extremely low risk acceptance.
- **Topology:** electrical power and fresh air must be brought into the 57 km long gallery running 2 km under ground level.

## 5 GENERAL TECHNICAL CONCEPT FOR THE RAILWAY EQUIPMENT

The relationship between the design parameters and some technical solutions is illustrated in the figure below:



**Figure 6: Technical solutions resulting from design specifications**

The technical solution developed by AlpTransit Gotthard fulfils all the project design specifications and consists fundamentally in:

- Twin tubes providing total physical separation between the two tracks.
- Two crossovers at about 1/3 and 2/3 of the tunnel length.
- Intermediate access galleries in Amsteg, Sedrun and Faido, from where the tunnel will be bored. Thereafter, two additional multifunctional stations will be integrated by the Sedrun and Faido crossovers, and will house power supply and signalling equipment, as well as specially ventilated «emergency stations» where passengers can be evacuated under optimum conditions.
- Cross passages which link the running tunnels every 325 meters. These passages will be used for evacuating passengers in case of emergencies and include some technical equipment necessary for the operation of the line.

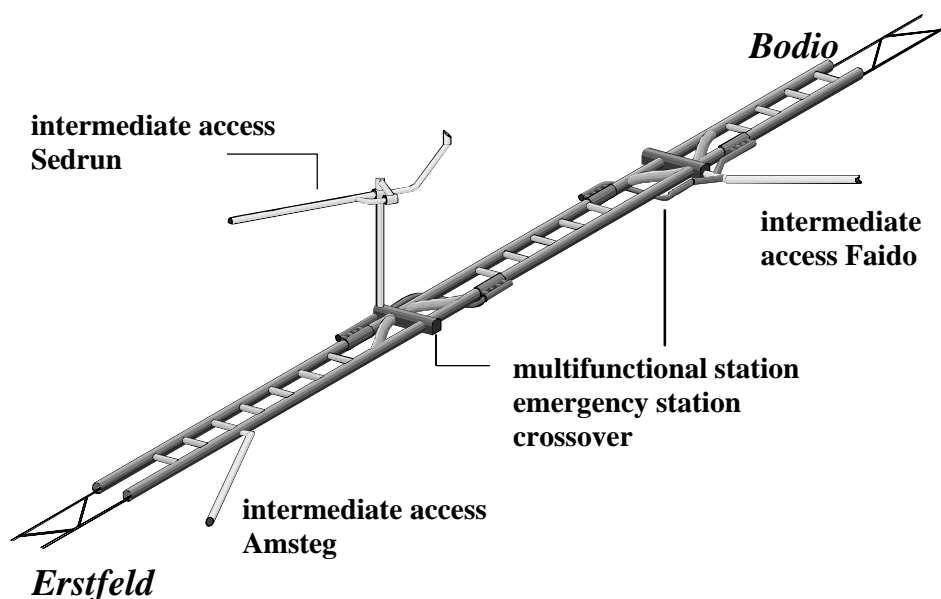

**Figure 7: The «Gotthard base tunnel» system**

### 5.1 Two fundamental guidelines and their consequences

Already at the very beginning of the project works, it became clear that the only way to ensure a coherent design of electromechanical equipment was to define some strict guidelines. The base for these guidelines can be found in the following three affirmations:

#### Every piece of equipment has to be maintained and will inevitably fail some day

Engineers usually like to build more and more complex systems, but many are unaware of the fact that the wild accumulation of subsystems often undermines the robustness and the availability of the whole.

#### Something which is never used will not work the day it has to

Many examples of past accidents show that emergency systems often fail at the moment they are first used under real or extreme conditions.

#### Equipment which is difficult to reach is difficult to maintain

Difficult accessibility induces high costs for maintenance.

The ensuing guideline defines the priorities for the location of electromechanical equipment:

*First guideline:*

- |                                     |   |
|-------------------------------------|---|
| 1) Outside the tunnel system:       | Easy access for maintenance in standard climatic conditions. Example: substation for traction power.  |
| 2) In the multifunctional stations: | Direct access and ventilation from the outside in standard climatic conditions. The areas used for logistics during tunnel construction can be reused. Examples: interlocking, power distribution.  |
| 3) In the cross passages:           | Physically isolated, to some extent, from the running tunnels. Basically, the same climatic conditions as in the tunnels. Poor accessibility. Examples: repeaters for data networks, low voltage distribution.  |
| 4) In the running tunnels:          | Worst climatic and mechanical conditions, dirty, poor accessibility. Only equipment which is absolutely needed for train operation or safety may be located there. Example: catenary, track, axle counters, leaky feeders, cables for power distribution and data transmission. |

The goals regarding the availability and efficiency of the equipment are illustrated in the next figure:

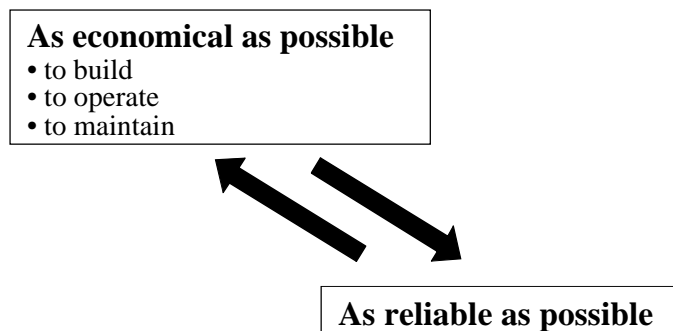

**Figure 8: Achieving economical and availability goals**

To fulfil the economic targets set by the available budgets, the global *Life Cycle Costs* for construction and operation of the whole transportation system must be kept as low as possible, which means limiting the amount of equipment to a reasonable minimum.

Considering the inherent complexity of the tunnel system and the extreme climatic and operating conditions, considering also that simple technical systems are much less prone to failure than more complex ones, the very high availability goals set by the project can only be reached by limiting the complexity of the equipment. At the same time, the very high safety target can only be achieved by using processes and systems which can be kept under control in all circumstances. When rarely occurring, unexpected situations arise, experience from past accidents has shown that very complex systems are often not mastered. The comparison between old very long railway tunnels and newer ones shows that there is a fundamental incompatibility between complexity and availability, whereas simplicity and availability have been shown to be synergetic.

As a result of these considerations, the following guideline for the Gotthard base tunnel's electromechanical equipment has been established :

*Second guideline:*

**KEEP IT SIMPLE!**

## 5.2 Track

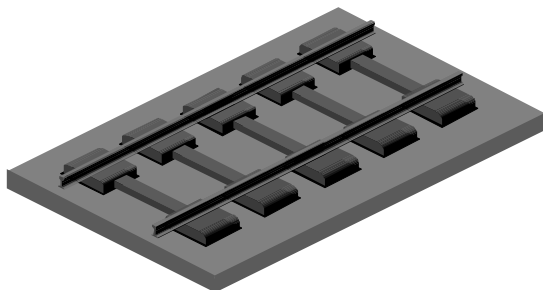

**Figure 9: Ballastless track**

A ballastless track will be used whose main advantages are very low maintenance costs and high reliability. These advantages are only partially counterbalanced by higher construction costs.

The number of points (at crossovers) is reduced to an absolute minimum. This reduction induces a reduction in maintenance volume, failures and risk of catastrophic derailments. The points cannot be completely eliminated as they are needed to allow for the necessary flexibility in operation.

Only large-radius curves, with a radius greater than 4000 m are designed, thus assuring higher travel speed and passenger comfort while reducing track wear, enhancing reliability and reducing maintenance.

## 5.3 Power supply for trains and electromechanical equipment

All electrical systems are made of standardised modules to simplify their installation, to keep the complexity of on-site maintenance as low as possible and to allow for uniform operating principles. In order to ensure that all requirements are identified properly and that the structure of the power supply system is appropriate, a very good co-ordination between all the different partners of the project is required, especially between suppliers and users of electrical power during the design phase of such systems.

To prevent any useless redundancies in the supply network, the power needs of every piece of equipment must be determined in terms of both quantity and quality. In addition, two completely independent systems must be completed:

- Firstly, the train power supply system in the tunnel, which consists mainly of substations, cables, switches and catenary whose properties are fundamentally governed by the profile of the line (slopes, aerodynamics) and by the operation concept (number, weight and velocity of trains). It is worth noting that the Swiss federal railways' own high voltage network is to be used because of the incompatibility between the  $16\frac{2}{3}$  Hz traction system and the usual 50 Hz public power grid.
- Secondly, the internal 50 Hz power supply in the tunnel used by most pieces of technical equipment (signalling, telecommunication, lighting, etc). For high safety and reliability, this fully redundant network is connected to the 50 Hz public power grid at all portals and intermediate accesses.

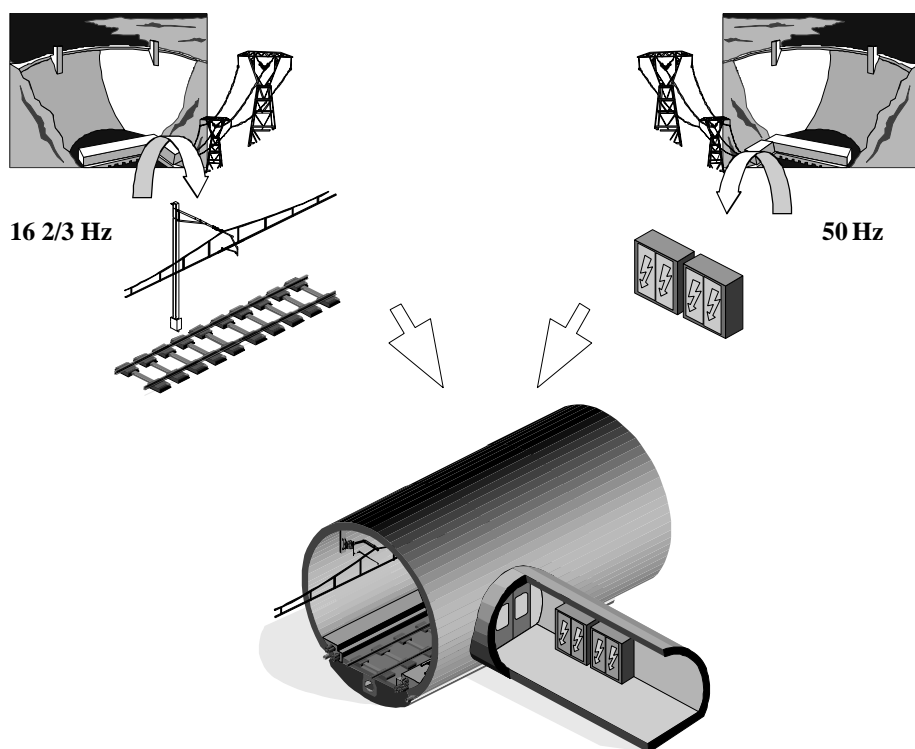

**Figure 10: Two fully independent electrical power supply networks**

To help prevent overruns in civil works, the cross-section of the tunnel has to be minimised. Given that the catenary is the electrical element with the greatest influence on the tunnel cross-section, it had to be optimised. This resulted in the design of a very compact double catenary system suitable for high speed and high power operation which was designed and successfully tested at speeds of over 200 km/h.



## 5.4 Signalling and telecommunication

The main innovative technologies which will be used in the Gotthard base tunnel are summarised in the following diagram and outlined thereafter :

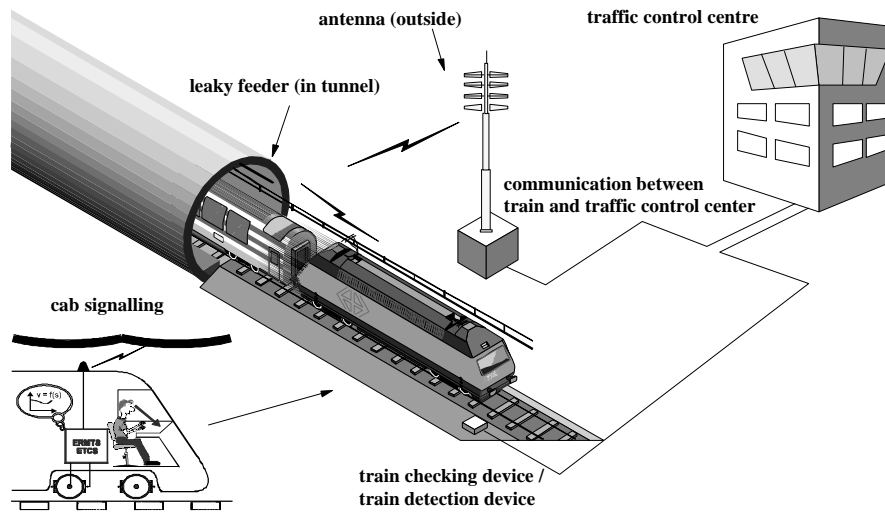

**Figure 11: Signalling and telecommunication**

- A cab-signalling system (ETCS/ERTMS level 2 without light signals) ensuring a continuous control of the position and speed of each train. This fail-safe system reduces the risk of excessive speed and collisions by several orders of magnitude compared to the current rail network.
- A permanent data and voice link between the trains and the control centre. This link is mainly used for transmission of data for the cab-signalling system and the public GSM network. In cases of emergencies, a prioritised access to the system can be allocated to rescue teams.
- A highly automated traffic control centre in which all the information relevant to tunnel operation (including trains control) and safety are centralised.
- Train checking devices such as hot brake detectors placed outside the tunnels some kilometres before the portals, thus ensuring that only trains in good condition enter the tunnel.

## 5.5 Maintenance

A new «generation» of maintenance concepts will be implemented on the new Swiss federal railways high speed lines, and especially in the tunnels. Their main characteristic is that commercial service is completely stopped during maintenance phases to free the track for the works. An appropriate timetable has to take these temporary restrictions into account.

In the Gotthard base tunnel, maintenance activities will take place about 200 days per year in one third of one of the running tunnels which will be closed for normal traffic and fully available for the maintenance teams during seven hours :

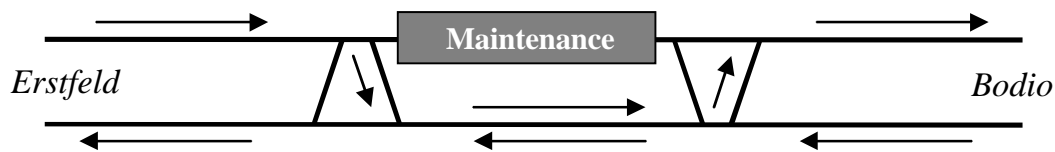

**Figure 12: Traffic during maintenance in the central east tube of the tunnel**

As can be seen on the above diagram, only one track will be available in part of the tunnel during maintenance work. This causes a significant reduction of transit capacity, but as the maintenance phases take place during the night, when there is almost no passenger traffic, this reduction is acceptable and counterbalanced by the much higher efficiency and safety achieved during maintenance works.

### 5.6 Additional equipment

According to the guideline «keep it simple», the electromechanical equipment in the tunnel should be reduced to a minimum. Nevertheless, some systems which can not be described as «railway equipment» will necessarily be installed, such as :

- Ventilation systems, which are required to ensure adequate climatic conditions in some technical rooms of the multifunction stations as well as smoke extraction equipment in the emergency stations. According to the climatic prognostics, artificial ventilation is neither required in the running tunnels nor in the cross-passages.
- Diverse other electromechanical systems (e.g. for opening and closing doors where automatic functioning is required).

## 6 CONCLUSION

The process described above and the resulting technical solutions represent a realistic answer to the challenge of constructing and operating a railway line through the 57 km long Gotthard base tunnel.

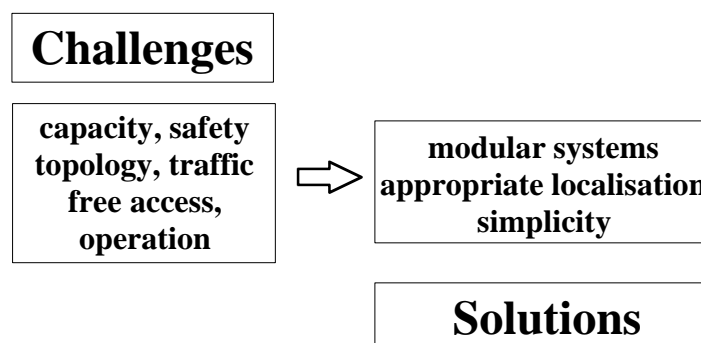

**Figure 13: A general philosophy for the planning of railway equipment**

Following some fundamental guidelines, it will be possible for the engineers to build a transportation system which fulfils the very demanding requirements regarding capacity, speed, availability and safety as well as ecology and financing.