



Using the VWDSP Interface
 Application Note #11

Overview

The VWDSP Interface provides the necessary excitation and signal processing to read 2 vibrating wire gages with their temperature devices. It uses analog and digital filtering techniques to insure a highly reliable vibrating wire measurement output. The temperature devices are read using a precision auto-sense (10 ranges) programmable current source so a wide variety of devices can be read.

In addition, the VWDSP includes multiplexer expansion capabilities, up to 8 multiplexers may be enabled through the Interface. The VWDSP can also clock multiplexers, contact Canary Systems or your hardware vendor for more information on this capability. The default mode is for the attached Control Module to provide the clocking signal to advance the multiplexer channels.

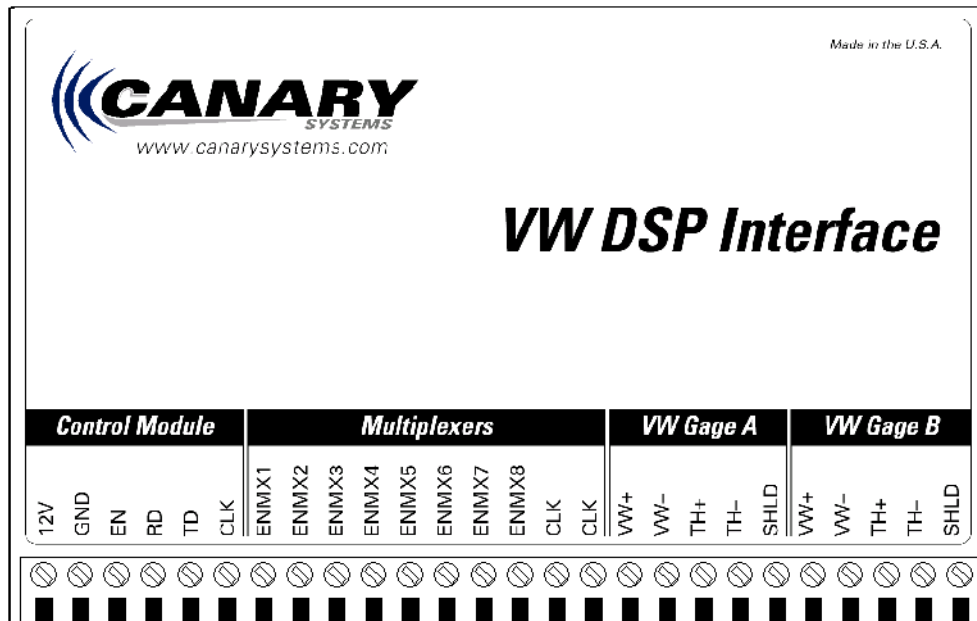

Control of the VWDSP is performed using simple ASCII based commands, transmitted using a serial data interface at 1200 bps.

Hardware Configuration

The VWDSP Interface provides a TTL or RS-232 level interface for connecting to the host device. The default interface is RS-232, contact Canary Systems or your product vendor to configure the interface for TTL. The VWDSP does not have data storage capability so it must be used in conjunction with other devices to deploy a data acquisition system. Typically it is used in conjunction with control modules such as the Campbell Scientific CR10X. This Application Note will primarily provide information to use the VWDSP with the CR10X Control Module.

The following table lists the **Control Module** and **RS-232** connections, brief descriptions and connection destinations for use with a PC, and for the CR10X, in both Non-MultiSensor Interface and MultiSensor Interface configurations. The MultiSensor Interface is a device manufactured by Canary Systems which facilitates connecting various types of instruments to a single multiplexer.

Label	Description	CR10X Non-MultiSensor	CR10X MultiSensor	CR800/CR850	CR1000	RS-232 Female DB-9
12V	Power supply input. Nominal voltage is 12V DC, range is 6V to 16V.	12V	12V	12V	12V	
GND	Power supply ground.	G	G	G	G	5 (Black)
EN	Enable input. If the VWDSP must be powered continuously then connect to 12V, otherwise connect to a digital control port to activate. Input range is 4V to VCC (power supply). DO NOT APPLY A HIGHER VOLTAGE THAN THE POWER SUPPLY!	C6	C8	C3	C7	4 (Red)
RD	Receive data input to the VWDSP. Default is RS-232 type, 1200bps, 8 data bits, 1 stop bit, no parity.	C4	C2	C1	C5	3 (White)
TD	Transmit data output to the VWDSP. Default is RS-232 type, 1200bps, 8 data bits, 1 stop bit, no parity.	C5	C3	C2	C6	2 (Green)
CLK	Multiplexer clock input. This connection is common to the Multiplexers CLK outputs. It is designed to facilitate expanding the CLK output to multiple multiplexers.	C8 (Note: The VWDSP can also generate the clocking signal to avoid using C8.)	NA	C4 (Note: The VWDSP can also generate the clocking signal to avoid using C4.)	C8 (Note: The VWDSP can also generate the clocking signal to avoid using C8.)	

The following schematic illustrates wiring of the VWDSP in a non-MultiSensor system with 2 multiplexers.

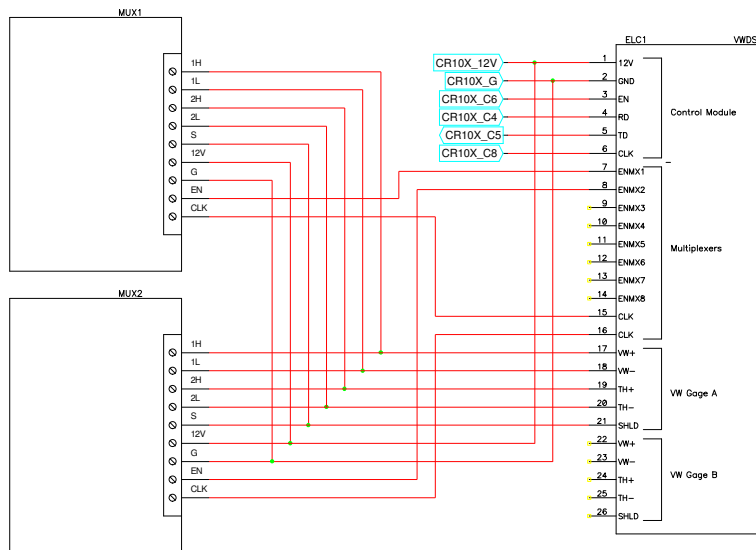

Command Interface

The VWDSP supports a simple ASCII based command set to configure, read and output measurements from the 2 vibrating wire channels. All commands are followed by a carriage return. The commands, with parameters, are as follows:

Cnnnn – Clock multiplexer, where n = 0001-0256. Alternately the C command can be issued without a 4 digit value to send a single clock pulse.

Mn – Enable multiplexer n, where n = 1-8. The respective ENMX1-ENMX8 output port is activated. If there is an existing port enabled it will be disabled prior to enabling the new port.

Pssss pppp cccc mmmm tttt – Configure the vibrating wire measurement.

Where;

ssss = Start frequency of excitation, in Hertz. Range is 0001-9999.

pppp = Stop frequency of excitation, in Hertz. Range is 0001-9999.

cccc = Number of frequency cycles. Range is 0001-9999. Recommended default is 500.

mmmm = Duration of sampling period in .01 seconds. Range is 0001-9999. Recommended default is 100 for a 1 second sampling period.

tttt = Width of frequency swath. Range is 0001-9999. Recommended default is 100.

For example, the following command configures the vibrating wire measurement for a start frequency of 400 Hertz, stop of 3500 Hertz, 500 excitation cycles, a 1 second sampling period and a swath of 100.

```
P0400 3500 0500 0100 0100
```

If the command is received properly then the VWDSP will respond with **OK**, otherwise **NG** will display.

VA – Output the vibrating wire measurement from Channel A. The output is in a raw data format, it must be converted to “digits” or period using simple math functions. The output consists of 4 values, separated by the space character and followed by a checksum. For example, consider the following example output:

```
*VA<CR>
```

```
VA734 733 112 60579 3A
```

```
*
```

The first value, 734, is the total of available counts.

The second value, 733, is the useable counts.

The third value, 112, is the Sum MSW, followed by the Sum LSW, 60579.

To convert these values to period multiply the Sum MSW (112) by 65536 and add to this result the Sum LSW (60579). Then divide the number of counts used into the Sum to derive counts per cycle, then multiply by the clock period, or 0.1356 μ s, for count period. For example, using the figures in the example above, the vibrating wire period is $((112*65536)+60579)/733*0.1356$ or 1369 μ s. Invert this to derive frequency, square and then multiply by 0.001 to derive digits. For example, $(1/.001369)^2*0.001 = 533$ digits. Divide useable counts into available counts to derive reading quality.

See the following section **CR10X Programming** for an example of this processing using Campbell programming instructions.

VB – Output the vibrating wire measurement from Channel B. See above for conversion to period or digits.

TA – Output the temperature device measurement from Channel A. The output is in a raw data format, it must be converted to resistance or temperature using simple math functions. The output consists of 2 values, separated by the space character and followed by a checksum.

Note: The VWDSP Firmware was updated beginning with version 8 (use the S command to verify the version of your unit) to output different units for the TA command. The following 2 sections will clarify the different output units.

Pre Version 8 Firmware

Consider the following example output:

```
*TA<CR>  
TA511 1014 94  
*
```

The first value, 511, is the excitation voltage, expressed in terms of the 10-bit (0-1023) range of the A/D converter. The second value, 1014, is the output voltage, expressed in terms of the 10-bit (0-1023) range of the A/D converter.

To convert these values to temperature first calculate the current used to power the temperature device. Divide the voltage input by 1023, multiply by the reference voltage and then divide by 1000 to derive the current. For example, $((511/1023)*4.775)/1000 = 0.002385A$. To derive the temperature device resistance subtract the input voltage from the output and divide by the current. For example, $((1014/1023)*4.775 - ((511/1023)*4.775)) / 0.002385 = 984 \text{ ohms}$.

Version 8 and Higher

```
*TA<CR> or TAnnnn<CR>  
TA00000 63800 B1  
*
```

The 2 values represent a MSW and LSW of the 10-bit A/D result of the voltage measurement. By default the VWDSP acquires 100 samples and sums the results. Use TAnnnn to specify alternate averaging, nnnn=number of samples to sum. The MSW represents the number of 65536 results, the LSW represents the remainder.

To convert these values to temperature first calculate the resistance of the thermistor. This requires 4 steps. First, calculate the voltage across the termination resistor (6040). $V_{tr} = (((0*65536)+63800)/100)/1023 * 2.5 = 1.559$ Second, calculate the current through the thermistor by dividing V_{tr} into the resistor value (6040). $I_r = 1.559/6040 = .000258$ Third, calculate the voltage across the current limiting resistor by multiplying the resistance (499) by the current (I_r). $V_r = 499 * .000258 = .1288$ Fourth, calculate the thermistor resistance by subtracting V_{tr} and V_r from the excitation voltage and then dividing by the current (I_r). $R = (2.5 - V_{tr} - V_r) / .000258 = (2.5 - 1.559 - .1288) / .000258 = 3148 \text{ ohms}$.

These formulas can be simplified but in their expanded form help explain the calculations performed.

The next step for either output is to convert the resistance values to temperature.

Conversion From Resistance to Temperature

The conversion from resistance to temperature will depend on the model of the temperature device. For example, a YSI44005 device would be converted to temperature using the following log equation:

$$T = \frac{1}{A + B(\ln R) + C(\ln R)^3} - 273.2$$

Where; T = Temperature in °C.
 LnR = Natural Log of Thermistor Resistance
 $A = 1.4051 \times 10^{-3}$
 $B = 2.369 \times 10^{-4}$
 $C = 1.019 \times 10^{-7}$

Using the example above the temperature is approximately 52.5°C for the <rev 8 firmware and approximately 24.0°C for the >= rev 8 firmware.

TB – Output the temperature device measurement from Channel B. See above for conversion to resistance or temperature.

MultiLogger Software Configuration

Support for the VWDSP is included in MultiLogger beginning in version 2.0.12. Contact Canary Systems or your software vendor to obtain an update. You can find the version of your software by selecting the menu item **Help | About**. NOTE: There have been important updates to MultiLogger in regards the functionality of the VWDSP, contact Canary Systems or your software vendor to obtain the software update information. Updates of MultiLogger are available without charge to registered users from our website.

There are 3 steps to the configuration of your system to use the VWDSP.

1. Configure the multiplexer Gage Type

If using the MultiSensor Interface then select **MultiSensor**, as shown below.

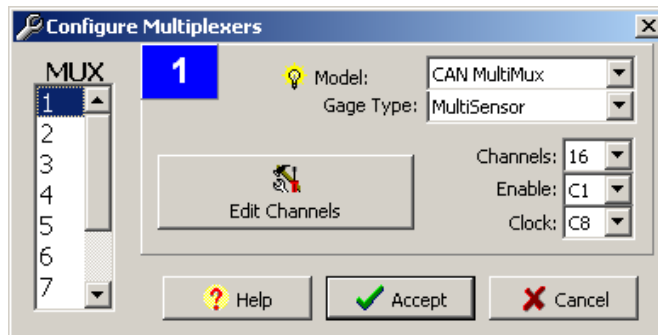

If NOT using the MultiSensor Interface then select **VWDSP**, as shown below.

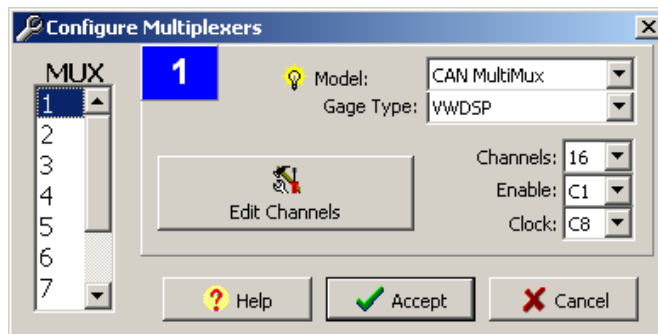

The Gage Type settings shown above relate to the wiring of your system. If you are not sure of the system wiring, or whether the system includes the MultiSensor Interface, then contact your hardware vendor for further direction.

2. Configure the Channel Gage Type

There are generic VWDSP gage types as well as model specific VWDSP gage types. It is highly recommended to use the model specific gage types wherever possible. Note how the selections are organized by Gage Type | Make | Model. The VWDSP types will have VWDSP in the Model name. For example, the screenshot below illustrates the correct setting for the Geokon VSM-4000 Vibrating Wire Strain Gage.

Contact Canary Systems or your software vendor for information regarding gages not listed.

The generic types are explained below.

The screenshot shows the 'Channel Configuration Multiplexer #1' dialog box. On the left, a list of channels from 1 to 16 is shown, with channel 1 selected. The main configuration area for channel 1 includes:

- Label:** SG1A
- Description:** Top Sensor
- Gage Type:** Vibrating Wire
- Make:** Geokon
- Model:** 4000VWDSP
- Conversion Method:** Linear (selected), Polynomial
- Linear Coefficients:** Zero Reading: 0.0, Gage Factor: 4.062, Offset: 0.0
- Polynomial Coefficients:** Coefficient A: 0.00000, Coefficient B: 1.00000, Coefficient C: 0.00000
- Units Conversion:** Units Type: Default, Input Units: None, Output Units: None
- Upper Channel (16CH Mode Only):** Label: Mux_1CH_3Temp, Device: None, Apply Temperature Correction: unchecked, Initial Temp: 0.00, Temp Factor: 0.000
- Check Alarms:** Type: None, Low Limit: 0.00, High Limit: 0.00

At the bottom, there are buttons for Print, Help, Accept, and Cancel.

The generic models available include:

VWDSP_REVB – Frequency range is 400 to 3500 Hz, digits output, uses channel A of the VWDSP.

VWDSP_REVB_B – Frequency range is 400 to 3500 Hz, digits output, uses channel B of the VWDSP.

VWDSP_REVB_P – Frequency range is 400 to 3500 Hz, period output (in microseconds), uses channel A of the VWDSP.

Note: The model specific gage types were added to MultiLogger beginning with version 2.1.2, it is highly recommended that you upgrade your version of MultiLogger if it pre-dates this version. Contact Canary Systems or your software vendor to obtain upgrade information. Upgrades are available without charge, via our website, to registered users of MultiLogger.

IMPORTANT NOTE: All of the Canary Systems VWDSP gage types utilize User Location 1 (default Input Storage location is 19) to report the measurement Quality, this value expressed as a percentage, represents the amount of data that was used, compared to the amount of data available, in the calculation of digits or period. The Canary Systems VWDSP selections use a threshold of 50% to determine validity of a measurement. Be aware that other Application Notes may describe using this location to store various parameters related to alarm monitoring or other uses, please select an alternate location when utilizing the Canary Systems VWDSP gage types.

3. Configure the Upper Channel (if 16 Channel multiplexer)

If the multiplexer Channels is set to 16 then a temperature may also be read by making the appropriate selection from the Upper Channel **Device** list. If the multiplexer Channels is set to 32 or 48 then the Upper Channel options will be disabled.

If using the MultiSensor Interface then select the appropriate Thermistor device, as shown below.

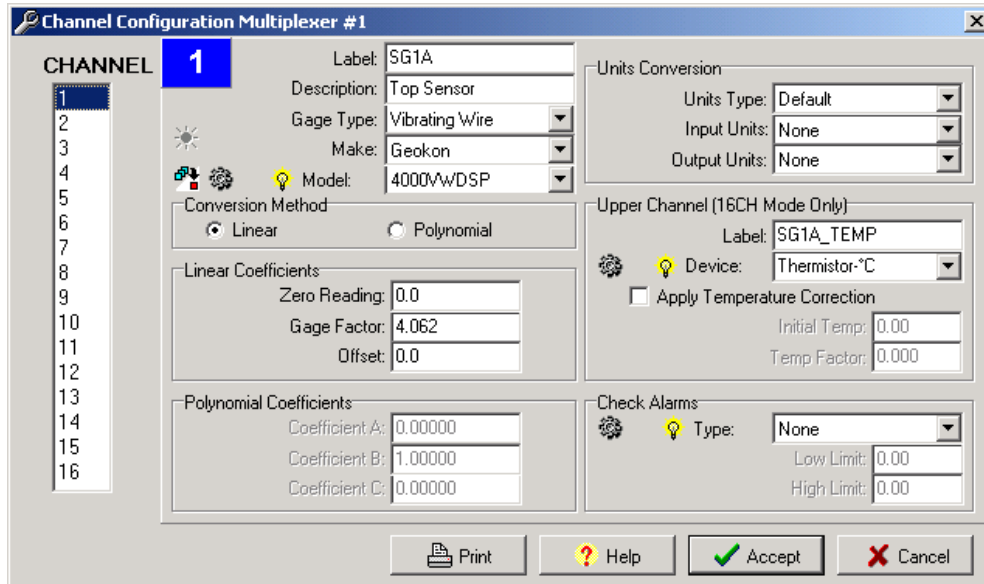

If NOT using the MultiSensor Interface then select the appropriate VWDSP Device, as shown below.

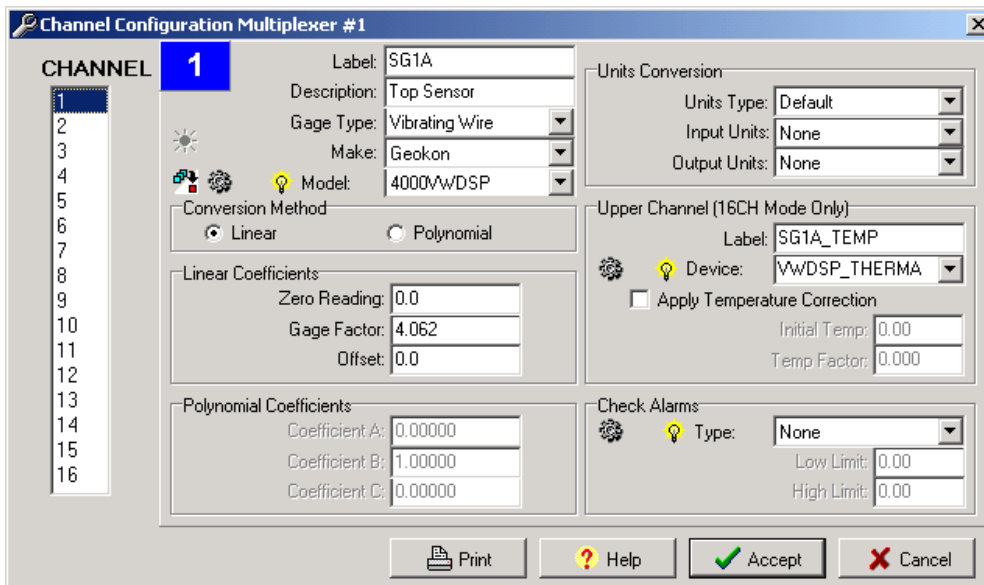

There are 4 VWDSP devices available:

- VWDSP_THERMA** – YSI44005 thermistor connected to the A channel with output in °C.
- VWDSP_THERMA°F** – YSI44005 thermistor connected to the A channel with output in °F.
- VWDSP_THERMB** - YSI44005 thermistor connected to the B channel with output in °C.
- VWDSP_THERMB°F** – YSI44005 thermistor connected to the B channel with output in °F.

CR10X Programming

If you are writing your own Campbell program instead of using MultiLogger the following code example, extracted from MultiLogger, serves to illustrate how to utilize the VWDSP. This example uses the non-MultiSensor system wiring and assumes the multiplexers are wired to use the A Channel. Output is in digits.

Some of the nomenclature that follows in this program example is unique to the MultiLogger construct of programming files. For example, the Loc references (Tdbyte1, Tdbyte2, etc.) should be converted to Input Storage location numbers (with an appropriate matching label) when using this code in a Campbell program.

The P command that is sent matches the example shown in the section **Command Interface**.

Consult the **Campbell CR10X Operators Manual** for additional information on the P15 instruction.

NOTE: This instruction example is broken into 3 sections, the first section describes the multiplexer activation and looping instructions, the second describes the vibrating wire measurement, the third describes the temperature measurement.

Turn On VWDSP and Clock Multiplexer Loop

```
;Sample VWDSP loop instructions

;Configure PORTS and turn on VWDSP
P20   Set Port(s)      ;
1: [4919              ] C8,C7,C6,C5 Options  ;
2: [9999              ] C4,C3,C2,C1 Options  ;
P22   Excitation with Delay ;
1: [01                ] Ex Channel      ;
2: [0000              ] Delay W/Ex (units = 0.01 sec) ;
3: [0010              ] Delay After Ex (units = 0.01 sec) ;
4: [0000              ] mV Excitation  ;

;Load M command
P30   Z=F              ;
1: [77.000            ] F                ;
2: [00                ] Exponent of 10 ;
3: [Tdbyte1           ] Z Loc                ] ;
P30   Z=F              ;
1: [49.000            ] F                ;
2: [00                ] Exponent of 10 ;
3: [Tdbyte2           ] Z Loc                ] ;
P30   Z=F              ;
1: [13.000            ] F                ;
2: [00                ] Exponent of 10 ;
3: [Tdbyte3           ] Z Loc                ] ;

;Send M Command
P15   Port Serial I/O ;
1: [01                ] Reps                ;
2: [01                ] P15 SERIAL I/O (ASCII/RS-232, 1200 Baud) ;
3: [0001              ] P15 Serial I/O (Delay (units = 0.01 sec)) ;
4: [03                ] First Control Port ;
5: [Tdbyte1           ] Output Loc          ] ;
6: [0003              ] No. of Locs to Send ;
7: [0000              ] Termination Character ;
8: [0000              ] Maximum Characters ;
9: [0000              ] CTS/Input Wait (units = 0.01 sec) ;
10: [Tdbyte1          ] Loc                  ] ;
11: [1.0000           ] Mult                ;
12: [0.0000           ] Offset              ;
```



```

P22      Excitation with Delay ;
1:[01      ]      ]      Ex Channel ;
2:[0000      ]      ]      Delay W/Ex (units = 0.01 sec) ;
3:[0010      ]      ]      Delay After Ex (units = 0.01 sec) ;
4:[0000      ]      ]      mV Excitation ;

;Mux read loop
P87      Beginning of Loop ;
1:[0      ]      ]      Delay ;
2:[16      ]      ]      Loop Count ;

;Advance the channel
P86      Do ;
1:[78      ]      ]      Command Code Option (Pulse Port 8) ;

;*****
;      CR10X Programming - Vibrating Wire Channel A Instructions Here
;*****

P31      Z=X ;
1:[ReadingLoc      ]      ]      X Loc ;
2:[Mux1Loc--      ]      ]      Z Loc ;

P95      End ;

;Turn off VWDSP
P86      Do ;
1:[56      ]      ]      Command Code Option (Set Port 6 Low) ;

```

Vibrating Wire Channel A

```

;Load P Command
P30      Z=F ;
1:[80      ]      ]      F ;
2:[0      ]      ]      Exponent of 10 ;
3:[TDbyte1      ]      ]      Z Loc ;

;Start
P30      Z=F ;
1:[48      ]      ]      F ;
2:[0      ]      ]      Exponent of 10 ;
3:[TDbyte2      ]      ]      Z Loc ;
P30      Z=F ;
1:[52      ]      ]      F ;
2:[0      ]      ]      Exponent of 10 ;
3:[TDbyte3      ]      ]      Z Loc ;
P30      Z=F ;
1:[48      ]      ]      F ;
2:[0      ]      ]      Exponent of 10 ;
3:[TDbyte4      ]      ]      Z Loc ;
P30      Z=F ;
1:[48      ]      ]      F ;
2:[0      ]      ]      Exponent of 10 ;
3:[TDbyte5      ]      ]      Z Loc ;
P30      Z=F ;
1:[32      ]      ]      F ;
2:[0      ]      ]      Exponent of 10 ;
3:[TDbyte6      ]      ]      Z Loc ;

;Stop
P30      Z=F ;
1:[51      ]      ]      F ;
2:[0      ]      ]      Exponent of 10 ;
3:[TDbyte7      ]      ]      Z Loc ;
P30      Z=F ;
1:[53      ]      ]      F ;
2:[0      ]      ]      Exponent of 10 ;
3:[TDbyte8      ]      ]      Z Loc ;
P30      Z=F ;
1:[48      ]      ]      F ;
2:[0      ]      ]      Exponent of 10 ;
3:[TDbyte9      ]      ]      Z Loc ;
P30      Z=F ;
1:[48      ]      ]      F ;
2:[0      ]      ]      Exponent of 10 ;
3:[TDbyte10     ]      ]      Z Loc ;
P30      Z=F ;
1:[32      ]      ]      F ;
2:[0      ]      ]      Exponent of 10 ;
3:[TDbyte11     ]      ]      Z Loc ;

;Cycles

```

```

P30      Z=F      ;
1:[48    ]        ]      F      ;
2:[0     ]        ]      Exponent of 10 ;
3:[TDbyte12]      ]      Z Loc  ;
P30      Z=F      ;
1:[54    ]        ]      F      ;
2:[0     ]        ]      Exponent of 10 ;
3:[TDbyte13]      ]      Z Loc  ;
P30      Z=F      ;
1:[48    ]        ]      F      ;
2:[0     ]        ]      Exponent of 10 ;
3:[TDbyte14]      ]      Z Loc  ;
P30      Z=F      ;
1:[48    ]        ]      F      ;
2:[0     ]        ]      Exponent of 10 ;
3:[TDbyte15]      ]      Z Loc  ;
P30      Z=F      ;
1:[32    ]        ]      F      ;
2:[0     ]        ]      Exponent of 10 ;
3:[TDbyte16]      ]      Z Loc  ;

;Sampling
P30      Z=F      ;
1:[48    ]        ]      F      ;
2:[0     ]        ]      Exponent of 10 ;
3:[TDbyte17]      ]      Z Loc  ;
P30      Z=F      ;
1:[49    ]        ]      F      ;
2:[0     ]        ]      Exponent of 10 ;
3:[TDbyte18]      ]      Z Loc  ;
P30      Z=F      ;
1:[48    ]        ]      F      ;
2:[0     ]        ]      Exponent of 10 ;
3:[TDbyte19]      ]      Z Loc  ;
P30      Z=F      ;
1:[48    ]        ]      F      ;
2:[0     ]        ]      Exponent of 10 ;
3:[TDbyte20]      ]      Z Loc  ;
P30      Z=F      ;
1:[32    ]        ]      F      ;
2:[0     ]        ]      Exponent of 10 ;
3:[TDbyte21]      ]      Z Loc  ;

;Swath
P30      Z=F      ;
1:[48    ]        ]      F      ;
2:[0     ]        ]      Exponent of 10 ;
3:[TDbyte22]      ]      Z Loc  ;
P30      Z=F      ;
1:[49    ]        ]      F      ;
2:[0     ]        ]      Exponent of 10 ;
3:[TDbyte23]      ]      Z Loc  ;
P30      Z=F      ;
1:[48    ]        ]      F      ;
2:[0     ]        ]      Exponent of 10 ;
3:[TDbyte24]      ]      Z Loc  ;
P30      Z=F      ;
1:[48    ]        ]      F      ;
2:[0     ]        ]      Exponent of 10 ;
3:[TDbyte25]      ]      Z Loc  ;

```

```

;Terminator
P30 Z=F ;
1:[13 ] F ;
2:[0 ] Exponent of 10 ;
3:[TDbyte26 ] Z Loc ;

;Load Read Command
P30 Z=F ;
1:[86 ] F ;
2:[0 ] Exponent of 10 ;
3:[TDbyte27 ] Z Loc ;
P30 Z=F ;
1:[65 ] F ;
2:[0 ] Exponent of 10 ;
3:[TDbyte28 ] Z Loc ;
P30 Z=F ;
1:[13 ] F ;
2:[0 ] Exponent of 10 ;
3:[TDbyte29 ] Z Loc ;

;Load S command
P30 Z=F ;
1:[83 ] F ;
2:[0 ] Exponent of 10 ;
3:[TDbyte30 ] Z Loc ;
P30 Z=F ;
1:[13 ] F ;
2:[0 ] Exponent of 10 ;
3:[TDbyte31 ] Z Loc ;

;Send S command and get results
P15 Port Serial I/O ;
1:[1 ] Reps ;
2:[1 ] P15:2 Serial I/O (8-Bit, RS-232 ASCII, 1200 Baud) ;
3:[1 ] P15:3 Serial I/O (Delay (0.01 sec units) before TX) ;
4:[3 ] First (RTS/DTR) of Control Ports Used ;
5:[TDbyte30 ] Start Loc for TX ;
6:[2 ] Number of Locs to TX ;
7:[42 ] Termination Character for RX ;
8:[5 ] Max Characters to RX ;
9:[100 ] P15:9 Serial I/O (Time Out for CTS (TX) and/or RX (0.01 sec units)) ;
10:[ScratchLoc1 ] Start Loc for RX ;
11:[1 ] Mult for RX ;
12:[0 ] Offset for RX ;

P63 Extended Parameters ;
1:[83 ] Option ;
2:[0 ] Option ;
3:[0 ] Option ;
4:[0 ] Option ;
5:[0 ] Option ;
6:[0 ] Option ;
7:[0 ] Option ;
8:[0 ] Option ;

;Make sure VWDSP responded before proceeding
P89 If (X<=>F) ;
1:[ScratchLoc1 ] X Loc ;
2:[3 ] Comparison Code Option (>=) ;
3:[0 ] F ;
4:[30 ] Command Code Option (Then Do) ;

;Short delay before P command
P22 Excitation with Delay ;
1:[1 ] Ex Channel ;
2:[0 ] Delay W/Ex (units = 0.01 sec) ;
3:[10 ] Delay After Ex (units = 0.01 sec) ;
4:[0 ] mV Excitation ;

```

```

;Send P command
P15      Port Serial I/O      ;
1:[1      ]      ]      Reps      ;
2:[1      ]      ]      P15:2 Serial I/O (8-Bit, RS-232 ASCII, 1200 Baud)      ;
3:[1      ]      ]      P15:3 Serial I/O (Delay (0.01 sec units) before TX)      ;
4:[3      ]      ]      First (RTS/DTR) of Control Ports Used      ;
5:[TDbyte1 ]      ]      Start Loc for TX      ;
6:[26     ]      ]      Number of Locs to TX      ;
7:[0      ]      ]      Termination Character for RX      ;
8:[0      ]      ]      Max Characters to RX      ;
9:[0      ]      ]      P15:9 Serial I/O      ;
10:[TDbyte1 ]      ]      Start Loc for RX      ;
11:[1     ]      ]      Mult for RX      ;
12:[0     ]      ]      Offset for RX      ;

P22      Excitation with Delay ;
1:[1      ]      ]      Ex Channel      ;
2:[0      ]      ]      Delay W/Ex (units = 0.01 sec)      ;
3:[10     ]      ]      Delay After Ex (units = 0.01 sec)      ;
4:[0      ]      ]      mV Excitation      ;
;Send VA command and get results
P15      Port Serial I/O      ;
1:[1      ]      ]      Reps      ;
2:[1      ]      ]      P15:2 Serial I/O (8-Bit, RS-232 ASCII, 1200 Baud)      ;
3:[10     ]      ]      P15:3 Serial I/O (Delay (0.01 sec units) before TX)      ;
4:[3      ]      ]      First (RTS/DTR) of Control Ports Used      ;
5:[TDbyte27 ]      ]      Start Loc for TX      ;
6:[3      ]      ]      Number of Locs to TX      ;
7:[42     ]      ]      Termination Character for RX      ;
8:[32     ]      ]      Max Characters to RX      ;
9:[1500   ]      ]      P15:9 Serial I/O (Time Out for CTS (TX) and/or RX (0.01 sec units))
;
10:[ScratchLoc1 ]      ]      Start Loc for RX      ;
11:[1      ]      ]      Mult for RX      ;
12:[0      ]      ]      Offset for RX      ;

P63      Extended Parameters      ;
1:[86     ]      ]      Option      ;
2:[65     ]      ]      Option      ;
3:[0      ]      ]      Option      ;
4:[0      ]      ]      Option      ;
5:[0      ]      ]      Option      ;
6:[0      ]      ]      Option      ;
7:[0      ]      ]      Option      ;
8:[0      ]      ]      Option      ;
;Make sure we have data from unit
P89      If (X<=>F)      ;
1:[ScratchLoc1 ]      ]      X Loc      ;
2:[1      ]      ]      Comparison Code Option (=)      ;
3:[-99999 ]      ]      F      ;
4:[30     ]      ]      Command Code Option (Then Do)      ;

P31      Z=X      ;
1:[ScratchLoc1 ]      ]      X Loc      ;
2:[ReadingLoc  ]      ]      Z Loc      ;

P94      Else      ;
;Calculate Result
P37      Z=X*F      ;
1:[ScratchLoc3 ]      ]      X Loc      ;
2:[65536      ]      ]      F      ;
3:[ScratchLoc5 ]      ]      Z Loc      ;

P33      Z=X+Y      ;
1:[ScratchLoc4 ]      ]      X Loc      ;
2:[ScratchLoc5 ]      ]      Y Loc      ;
3:[ScratchLoc5 ]      ]      Z Loc      ;

P38      Z=X/Y      ;
1:[ScratchLoc5 ]      ]      X Loc      ;
2:[ScratchLoc2 ]      ]      Y Loc      ;
3:[ScratchLoc5 ]      ]      Z Loc      ;

```

```

P37      Z=X*F ;
1:[ScratchLoc5      ]      X Loc ;
2:[0.1356           ]      F ;
3:[ScratchLoc5      ]      Z Loc ;

P42      Z=1/X ;
1:[ScratchLoc5      ]      X Loc ;
2:[ScratchLoc5      ]      Z Loc ;

P37      Z=X*F ;
1:[ScratchLoc5      ]      X Loc ;
2:[1000             ]      F ;
3:[ScratchLoc5      ]      Z Loc ;

P37      Z=X*F ;
1:[ScratchLoc5      ]      X Loc ;
2:[1000             ]      F ;
3:[ScratchLoc5      ]      Z Loc ;

P36      Z=X*Y ;
1:[ScratchLoc5      ]      X Loc ;
2:[ScratchLoc5      ]      Y Loc ;
3:[ScratchLoc5      ]      Z Loc ;

P37      Z=X*F ;
1:[ScratchLoc5      ]      X Loc ;
2:[0.001            ]      F ;
3:[ScratchLoc5      ]      Z Loc ;

P37      Z=X*F ;
1:[ScratchLoc5      ]      X Loc ;
2:[0.001            ]      F ;
3:[ReadingLoc       ]      Z Loc ;
;Calculate Goodness
P38      Z=X/Y ;
1:[ScratchLoc2      ]      X Loc ;
2:[ScratchLoc1      ]      Y Loc ;
3:[ScratchLoc6      ]      Z Loc ;

P37      Z=X*F ;
1:[ScratchLoc6      ]      X Loc ;
2:[100              ]      F ;
3:[UserLoc1         ]      Z Loc ;
;Check Quality
P89      If (X<=>F) ;
1:[UserLoc1         ]      X Loc ;
2:[4                ]      Comparison Code Option (<) ;
3:[50               ]      F ;
4:[30               ]      Command Code Option (Then Do) ;
P30      Z=F ;
1:[-99998           ]      F ;
2:[0                ]      Exponent of 10 ;
3:[ReadingLoc       ]      Z Loc ;
P94      Else ;
P89      If (X<=>F) ;
1:[ScratchLoc2      ]      X Loc ;
2:[4                ]      Comparison Code Option (<) ;
3:[100              ]      F ;
4:[30               ]      Command Code Option (Then Do) ;
P30      Z=F ;
1:[-99997           ]      F ;
2:[0                ]      Exponent of 10 ;
3:[ReadingLoc       ]      Z Loc ;
P95      End ;
P95      End ;
P95      End ;
;Else VWDSP is not responding
P94      Else ;
P31      Z=X ;
1:[ScratchLoc1      ]      X Loc ;
2:[ReadingLoc       ]      Z Loc ;

P95      End ;

```

CR10X Temperature

The following code example illustrates how to read a YSI44005 type thermistor using the A channel of the VWDSP, with output in °C.

```
P30      Z=F      ;
1:[83      ]      F      ;
2:[0      ]      Exponent of 10 ;
3:[TDbyte1 ]      Z Loc  ;
P30      Z=F      ;
1:[13      ]      F      ;
2:[0      ]      Exponent of 10 ;
3:[TDbyte2 ]      Z Loc  ;

;Load Read Command
P30      Z=F      ;
1:[84      ]      F      ;
2:[0      ]      Exponent of 10 ;
3:[TDbyte3 ]      Z Loc  ;
P30      Z=F      ;
1:[65      ]      F      ;
2:[0      ]      Exponent of 10 ;
3:[TDbyte4 ]      Z Loc  ;
P30      Z=F      ;
1:[13      ]      F      ;
2:[0      ]      Exponent of 10 ;
3:[TDbyte5 ]      Z Loc  ;
;Send S command and get results
P15      Port Serial I/O
;
1:[1      ]      Reps      ;
2:[1      ]      P15:2 Serial I/O (8-Bit, RS-232 ASCII, 1200 Baud) ;
3:[10     ]      P15:3 Serial I/O (Delay (0.01 sec units) before TX) ;
4:[3      ]      First (RTS/DTR) of Control Ports Used ;
5:[TDbyte1]      Start Loc for TX ;
6:[2      ]      Number of Locs to TX ;
7:[42     ]      Termination Character for RX ;
8:[8      ]      Max Characters to RX ;
9:[50     ]      P15:9 Serial I/O (Time Out for CTS (TX) and/or RX (0.01 sec units))
10:[ScratchLoc10] Start Loc for RX ;
11:[1     ]      Mult for RX ;
12:[0     ]      Offset for RX ;
;Use S filter string
P63      Extended Parameters ;
1:[83      ]      Option ;
2:[0      ]      Option ;
3:[0      ]      Option ;
4:[0      ]      Option ;
5:[0      ]      Option ;
6:[0      ]      Option ;
7:[0      ]      Option ;
8:[0      ]      Option ;
;Check for S command received before proceeding
P89      If (X<=>F) ;
1:[ScratchLoc10] X Loc ;
2:[3      ]      Comparison Code Option (>=) ;
3:[0      ]      F ;
4:[30     ]      Command Code Option (Then Do) ;
;Send TA command and get results
P15      Port Serial I/O
;
1:[1      ]      Reps      ;
2:[1      ]      P15:2 Serial I/O (8-Bit, RS-232 ASCII, 1200 Baud) ;
3:[10     ]      P15:3 Serial I/O (Delay (0.01 sec units) before TX) ;
4:[3      ]      First (RTS/DTR) of Control Ports Used ;
5:[TDbyte3]      Start Loc for TX ;
6:[3      ]      Number of Locs to TX ;
7:[42     ]      Termination Character for RX ;
8:[20     ]      Max Characters to RX ;
9:[200    ]      P15:9 Serial I/O (Time Out for CTS (TX) and/or RX (0.01 sec units))
10:[ScratchLoc1] Start Loc for RX ;
11:[1     ]      Mult for RX ;
12:[0     ]      Offset for RX ;

;Use TA filter string
P63      Extended Parameters ;
1:[84      ]      Option ;
2:[65      ]      Option ;
3:[0      ]      Option ;
4:[0      ]      Option ;
5:[0      ]      Option ;
6:[0      ]      Option ;
7:[0      ]      Option ;
```

```

8:[0          ]      Option ;

;Make sure we have a result from VWDSP
P89  If (X<=>F)      ;
1:[ScratchLoc1     ]      X Loc ;
2:[4              ]      Comparison Code Option (<) ;
3:[0              ]      F ;
4:[30             ]      Command Code Option (Then Do) ;

P30  Z=F ;
1:[-99.99         ]      F ;
2:[0              ]      Exponent of 10 ;
3:[ReadingLoc     ]      Z Loc ;

P94  Else ;

;Calculate Result for < v7 FW
P89  If (X<=>F)      ;
1:[ScratchLoc10    ]      X Loc ;
2:[4              ]      Comparison Code Option (<) ;
3:[8              ]      F ;
4:[30             ]      Command Code Option (Then Do) ;

P30  Z=F ;
1:[1023           ]      F ;
2:[0              ]      Exponent of 10 ;
3:[ScratchLoc3    ]      Z Loc ;

P38  Z=X/Y ;
1:[ScratchLoc1     ]      X Loc ;
2:[ScratchLoc3    ]      Y Loc ;
3:[ScratchLoc4    ]      Z Loc ;

P37  Z=X*F ;
1:[ScratchLoc4     ]      X Loc ;
2:[4.700          ]      F ;
3:[ScratchLoc4    ]      Z Loc ;

P37  Z=X*F ;
1:[ScratchLoc4     ]      X Loc ;
2:[0.001          ]      F ;
3:[ScratchLoc5    ]      Z Loc ;

P38  Z=X/Y ;
1:[ScratchLoc2     ]      X Loc ;
2:[ScratchLoc3    ]      Y Loc ;
3:[ScratchLoc6    ]      Z Loc ;

P37  Z=X*F ;
1:[ScratchLoc6     ]      X Loc ;
2:[4.700          ]      F ;
3:[ScratchLoc6    ]      Z Loc ;

P35  Z=X-Y ;
1:[ScratchLoc6     ]      X Loc ;
2:[ScratchLoc4    ]      Y Loc ;
3:[ScratchLoc7    ]      Z Loc ;

P38  Z=X/Y ;
1:[ScratchLoc7     ]      X Loc ;
2:[ScratchLoc5    ]      Y Loc ;
3:[ScratchLoc7    ]      Z Loc ;

```

```

;Else calculate result for > v8 FW
P94   Else   ;

;Multiple MSW
P37   Z=X*F   ;
1:[ScratchLoc1   ]   X Loc   ;
2:[65536         ]   F       ;
3:[ScratchLoc1   ]   Z Loc   ;

;Add our LSW
P33   Z=X+Y   ;
1:[ScratchLoc1   ]   X Loc   ;
2:[ScratchLoc2   ]   Y Loc   ;
3:[ScratchLoc3   ]   Z Loc   ;

;Divide for our averaging
P37   Z=X*F   ;
1:[ScratchLoc3   ]   X Loc   ;
2:[0.01          ]   F       ;
3:[ScratchLoc3   ]   Z Loc   ;

P30   Z=F     ;
1:[1023          ]   F       ;
2:[0             ]   Exponent of 10 ;
3:[ScratchLoc4   ]   Z Loc   ;

P38   Z=X/Y   ;
1:[ScratchLoc3   ]   X Loc   ;
2:[ScratchLoc4   ]   Y Loc   ;
3:[ScratchLoc4   ]   Z Loc   ;

P37   Z=X*F   ;
1:[ScratchLoc4   ]   X Loc   ;
2:[2.5           ]   F       ;
3:[ScratchLoc4   ]   Z Loc   ;

P30   Z=F     ;
1:[6040          ]   F       ;
2:[0             ]   Exponent of 10 ;
3:[ScratchLoc5   ]   Z Loc   ;

P38   Z=X/Y   ;
1:[ScratchLoc4   ]   X Loc   ;
2:[ScratchLoc5   ]   Y Loc   ;
3:[ScratchLoc5   ]   Z Loc   ;

P37   Z=X*F   ;
1:[ScratchLoc5   ]   X Loc   ;
2:[499           ]   F       ;
3:[ScratchLoc6   ]   Z Loc   ;

P30   Z=F     ;
1:[2.5           ]   F       ;
2:[0             ]   Exponent of 10 ;
3:[ScratchLoc7   ]   Z Loc   ;

P35   Z=X-Y   ;
1:[ScratchLoc7   ]   X Loc   ;
2:[ScratchLoc4   ]   Y Loc   ;
3:[ScratchLoc7   ]   Z Loc   ;

P35   Z=X-Y   ;
1:[ScratchLoc7   ]   X Loc   ;
2:[ScratchLoc6   ]   Y Loc   ;
3:[ScratchLoc7   ]   Z Loc   ;

P38   Z=X/Y   ;
1:[ScratchLoc7   ]   X Loc   ;
2:[ScratchLoc5   ]   Y Loc   ;
3:[ScratchLoc7   ]   Z Loc   ;

P95   End     ;

```



```

;Resistance should be in ScratchLoc7
P40     Z=LN(X) ;
1:[ScratchLoc7      ]      X Loc  ;
2:[ScratchLoc8      ]      Z Loc  ;

P30     Z=F      ;
1:[2.369            ]      F        ;
2:[4--              ]      Exponent of 10 ;
3:[ScratchLoc9      ]      Z Loc  ;

P36     Z=X*Y    ;
1:[ScratchLoc8      ]      X Loc  ;
2:[ScratchLoc9      ]      Y Loc  ;
3:[ScratchLoc8      ]      Z Loc  ;

P40     Z=LN(X) ;
1:[ScratchLoc7      ]      X Loc  ;
2:[ScratchLoc9      ]      Z Loc  ;

P36     Z=X*Y    ;
1:[ScratchLoc9      ]      X Loc  ;
2:[ScratchLoc9      ]      Y Loc  ;
3:[ScratchLoc10     ]      Z Loc  ;

P36     Z=X*Y    ;
1:[ScratchLoc9      ]      X Loc  ;
2:[ScratchLoc10     ]      Y Loc  ;
3:[ScratchLoc9      ]      Z Loc  ;

P30     Z=F      ;
1:[1.019            ]      F        ;
2:[7--              ]      Exponent of 10 ;
3:[ScratchLoc10     ]      Z Loc  ;

P36     Z=X*Y    ;
1:[ScratchLoc9      ]      X Loc  ;
2:[ScratchLoc10     ]      Y Loc  ;
3:[ScratchLoc9      ]      Z Loc  ;

P30     Z=F      ;
1:[1.4051           ]      F        ;
2:[3--              ]      Exponent of 10 ;
3:[ScratchLoc10     ]      Z Loc  ;

P33     Z=X+Y    ;
1:[ScratchLoc9      ]      X Loc  ;
2:[ScratchLoc10     ]      Y Loc  ;
3:[ScratchLoc10     ]      Z Loc  ;
P33     Z=X+Y    ;
1:[ScratchLoc8      ]      X Loc  ;
2:[ScratchLoc10     ]      Y Loc  ;
3:[ScratchLoc10     ]      Z Loc  ;

P42     Z=1/X    ;
1:[ScratchLoc10     ]      X Loc  ;
2:[ScratchLoc10     ]      Z Loc  ;

P34     Z=X+F    ;
1:[ScratchLoc10     ]      X Loc  ;
2:[273.2--          ]      F        ;
3:[ReadingLoc       ]      Z Loc  ;

P95     End      ;

;No S command received - no VWDSP connected?
P94     Else      ;

P31     Z=X      ;
1:[ScratchLoc10     ]      X Loc  ;
2:[ReadingLoc       ]      Z Loc  ;

P95     End      ;

```

CR1000 Programming

If you are writing your own Campbell program instead of using MultiLogger the following code example, extracted from MultiLogger, serves to illustrate how to utilize the VWDSP. Output is in digits.

Some of the nomenclature that follows in this program example is unique to the MultiLogger construct of programming files. You will need to DIM ScratchLoc(10) as well as define a string buffer, sInBuf, to store the response string from the VWDSP.

```
'Turn on VWDSP Power
PortSet (7,1)
'Wait for power up
Delay(0,100,MSEC)
'Open our serial port
SerialOpen (8,1200,0,1000,255)

'Check that the VWDSP is present by sending S command
Delay (0,10,mSec)
ScratchLoc(1) = SerialOut (8,"S"+CHR(13),"",2,50)

'Check for valid response
if ScratchLoc(1) <> 0 then

    'Short delay
    Delay (0,100,mSec)
    'Send P command
    SerialOut (8,"P0400 3500 0600 0040 0300"+CHR(13),"",0,0)
    'Short delay
    Delay (0,350,mSec)
    'Make sure buffer is clear
    SerialFlush(8)
    'Send VA command
    SerialOut (8,"VA"+CHR(13),"",0,0)
    'Receive response
    SerialIn(sInBuf,8,1500,-1,30)

    if Len(sInBuf) >= 30 then
        'Split out response values
        Splitstr(ScratchLoc(),sInBuf," ",4,0)

        'Convert to reading
        ScratchLoc(5) = 1/(((ScratchLoc(3)*65536)+ScratchLoc(4))/ScratchLoc(2))*0.1356)
        ScratchLoc(5) = (ScratchLoc(5) * 1000000)^2
        ScratchLoc(5) = ScratchLoc(5) * 0.001 'Convert to Digits otherwise f^2x10-9
        Reading_Loc = ScratchLoc(5) * 0.001

        'Calculate quality
        mlUser1 = (ScratchLoc(2) / ScratchLoc(1)) * 100

        'Error - poor quality
        if mlUser1 < 50 then Reading_Loc = -99.998

        'Error - not enough data
        if ScratchLoc(2) < 50 then Reading_Loc = -99.997

    'No valid response
    Else
        Reading_Loc = -99.999
    EndIf

'No valid response
Else
    Reading_Loc = -99.999
EndIf

'Turn off VWDSP Power
PortSet (7,0)
'Close our serial port
SerialClose (8)
```

CR1000 Temperature

The following code example illustrates how to program a CR1000 to read a YSI44005 type thermistor connected to the input channel A of the VWDSP. The firmware revision is checked for temperature conversion method.

```
'Read a YSI44005 thermistor with the VWDSP Channel A - output C

'Turn on VWDSP Power
PortSet (7,1)
'Wait for power up
Delay(0,100,MSEC)
'Open our serial port
SerialOpen (8,1200,0,1000,255)
'Short delay before commands
Delay (0,50,mSec)

'Check our VWDSP version to determine results processing
SerialFlush(8)
SerialOut(8,"S"+CHR(13),"",0,0)
SerialIn(sInBuf,8,50,"*",12)
SplitStr(ScratchLoc(10),sInBuf," ",2,0)

'Make sure we have version before proceeding
if ScratchLoc(10) > 0 then

    SerialFlush(8)
    SerialOut (8,"TA"+CHR(13),"",0,0)
    SerialIn(sInBuf,8,100,-1,18)

    if Len(sInBuf) > 16 then

        SplitStr(ScratchLoc(),sInBuf," ",2,0)

        'Check FW to determine how to convert results
        if ScratchLoc(10) < 8 then
            'Convert to resistance
            ScratchLoc(4) = (ScratchLoc(1) / 1023) * 4.775
            ScratchLoc(5) = ScratchLoc(4) * 0.001
            ScratchLoc(6) = (ScratchLoc(2) / 1023) * 4.775
            ScratchLoc(7) = (ScratchLoc(6) - ScratchLoc(4))/ScratchLoc(5)
        else
            ScratchLoc(3) = ((ScratchLoc(1) * 65536) + ScratchLoc(2)) / 100

            ScratchLoc(4) = ((ScratchLoc(3)/1023)*2.5)
            ScratchLoc(5) = ScratchLoc(4) / 6040
            ScratchLoc(6) = ScratchLoc(5) * 499
            ScratchLoc(7) = (2.5 - ScratchLoc(4) - ScratchLoc(6)) / ScratchLoc(5)
        endif

        'Use Steinhart/Hart to convert resistance to temperature
        mlReading = 1/(.0014051+(.0002369*Log(ScratchLoc(7))) +
(.0000001019*(Log(ScratchLoc(7))^3))) - 273.2

        'Check range before finishing
        if mlReading > 100 then mlReading = -99.8

        else
            mlReading = -99.9
        endif

    else
        mlReading = -99999
    endif

'Turn off VWDSP Power
PortSet (7,0)
'Close our serial port
SerialClose (8)
```